

TYPE K-AGG-01

Motor unit



Art.Nr.: 10042078

21-06-2013 | Version 1.2 | EN

Kugelmann Maschinenbau e.K.
Gewerbepark 1-5
87675 Rettenbach a.A.
GERMANY

www.kugelmann.com
office@kugelmann.com
+49 (0) 8860 | 9190-0

*

Kugelmann Maschinenbau is a family-run Allgäu business with its main emphasis and tradition in municipal technology. With passion, we manufacture reliable and pioneering machines - we love what we do.

Copyrights and trademarks

© Kugelmann Maschinenbau e.K.

Gewerbepark 1-5

D – 87675 Rettenbach a.A.

Tel.: +49 (0) 8860 / 9190-0

Fax: +49 (0) 8860 / 9190-19

Mail: office@kugelmann.com

Web: www.kugelmann.com

All company names and designations used in this manual are possibly registered trademarks of the respective manufacturing companies and may not be used commercially or otherwise. Errors and omissions excepted.

All rights reserved; no part of this manual may be copied, reproduced or multiplied in any form (printing, photocopying, saving and/or distribution in electronic form) without express written permission of Kugelmann e.K.

We are constantly developing our products further to provide you with top comfort and convenience. We ask you to understand that the manual can therefore deviate from the product in some regards.

Content

- 1 Title..... 1**
- 2 General information.....5**
 - 2.1 Identification.....5
 - 2.2 Service information..... 6
 - 2.3 EC Declaration of Conformity in terms of the EC Machinery Directive 2006/42/EC..... 7
- 3 Operating instructions..... 8**
 - 3.1 Target group..... 8
 - 3.2 Use..... 8
 - 3.3 Conventions..... 9
 - 3.4 Change history..... 9
- 4 General description..... 10**
 - 4.1 Components..... 10
 - 4.2 Designated use..... 12
 - 4.3 Obvious misuse..... 12
- 5 Safety instructions..... 13**
 - 5.1 General safety instructions..... 13
 - 5.2 Special safety instructions..... 13
 - 5.3 Transport..... 14
 - 5.4 Operation..... 14
 - 5.5 Maintenance and inspection..... 15
 - 5.6 Designation..... 16
- 6 Commissioning..... 17**
 - 6.1 Hoses and pipelines..... 17
 - 6.2 Oil filling..... 17

| | |
|---|-----------|
| 7 Operating instructions..... | 20 |
| 7.1 Normal and safe operation..... | 20 |
| 7.2 Remote control..... | 22 |
| 7.2.1 Design..... | 22 |
| 7.2.2 Operating elements..... | 23 |
| 7.2.3 Starting the motor unit..... | 24 |
| 7.2.4 Switching off the motor unit..... | 25 |
| 7.3 Extraordinary situations..... | 27 |
| 8 Maintenance..... | 28 |
| 8.1 Maintenance intervals..... | 28 |
| 8.2 Cleaning of hydraulic oil suction filter..... | 29 |
| 8.3 Change of hydraulic oil return filter..... | 31 |
| 9 Transport..... | 32 |
| 10 Storage..... | 33 |
| 11 Hints relating to assembly and disassembly..... | 34 |
| 12 Disconnecting the system..... | 35 |
| 13 Technical Data..... | 36 |
| 14 Spare parts list..... | 37 |
| Appendix..... | 40 |
| Index..... | 43 |
| Guarantee..... | 45 |

2 General information

This chapter gives you information on the following:

- Identification of motor unit
- Customer service
- EC Declaration of Conformity

2.1 Identification

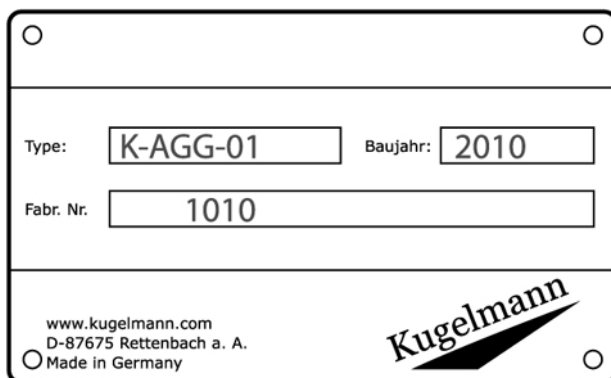

The type plate refers to device type, year of construction, serial number, and manufacturer.

You will find the type plate at the left side next to the control panel at the left side of the motor unit.

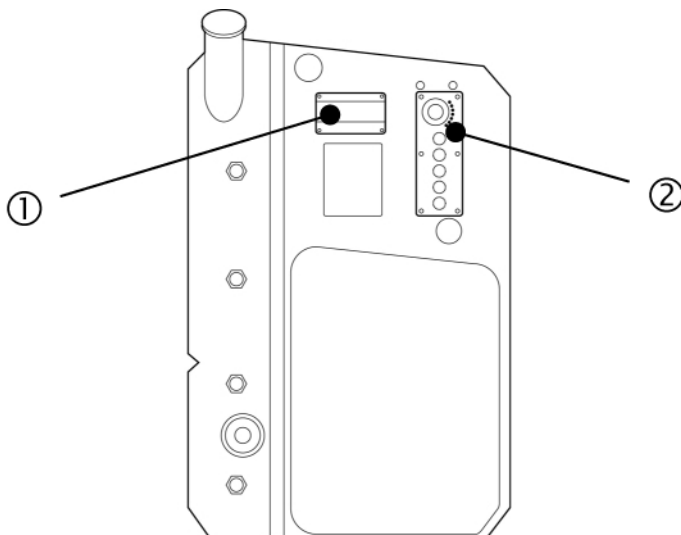

| Pos.-Nr. | Function |
|----------|---------------|
| 1 | Type plate |
| 2 | Control panel |

2.2 Service information

Customer service:

Tel.: +49 (0) 8860 / 9190-90

Fax: +49 (0) 8860 / 9190-49

E-Mail: service@kugelmann.com

2.3 EC Declaration of Conformity in terms of the EC Machinery Directive 2006/42/EC



We herewith declare that the machine designated below complies with the relevant essential health and safety requirements of the respective EC Directives as well as with the standards, guidelines and other regulations mentioned below due to its design and construction, and in the version supplied by us.

If the machine is modified without our consent, this declaration shall cease to apply.

Designation: Motor unit

Machine type: K-AGG-01

Relevant EC machinery directives:

EN standards:

EN ISO 12100-1, EN ISO 12100-2, EN ISO 4254-1

EMC standards:

72/245/EG in version 2005/83/EG

Rettenbach a.A., September 2010

Josef Kugelmann

3 Operating instructions

This chapter gives you information on the following:

- Target group
- Correct use of these operating instructions
- Conventions used
- Possible changes compared to previous versions

3.1 Target group

These operating instructions are intended for the operator of the motor unit. You will find instructions relating to the proper operation and the necessary maintenance work.

3.2 Use





Before first commissioning of the motor unit, please study these operating instructions thoroughly and completely.

These operating instructions are part of the product and have to be kept in a safe place. In case of resale or transfer of the machine to third parties, these operating instructions have to be included.

All information, illustrations and technical data correspond to the technical state at the time of printing. Subject to technical modifications.

3.3 Conventions

This manual uses the following typographic conventions:

| Symbol | Signal word | Meaning |
|---|-------------|---|
|  | Danger | Describes an imminently hazardous situation. Death or serious injury could result. |
|  | Warning | Describes a situation that could possibly be hazardous. Death or serious injury could result. |
|  | Caution | Describes a situation that could possibly be hazardous. Minor injuries or material damage could result. |
|  | Advice | Contains useful information on correct handling of and conduct around the machine. |

3.4 Change history

| Date | Version | Change |
|------------|---------|---|
| 27-09-2010 | 1.0 | First edition |
| 17-01-2011 | 1.1 | Second edition with extended spare parts list |
| 21-06-2013 | 1.2 | Third edition with extended spare parts list |

4 General description

This chapter gives information on the design of the motor unit and its designated use.

4.1 Components

Overview on front face of motor unit:

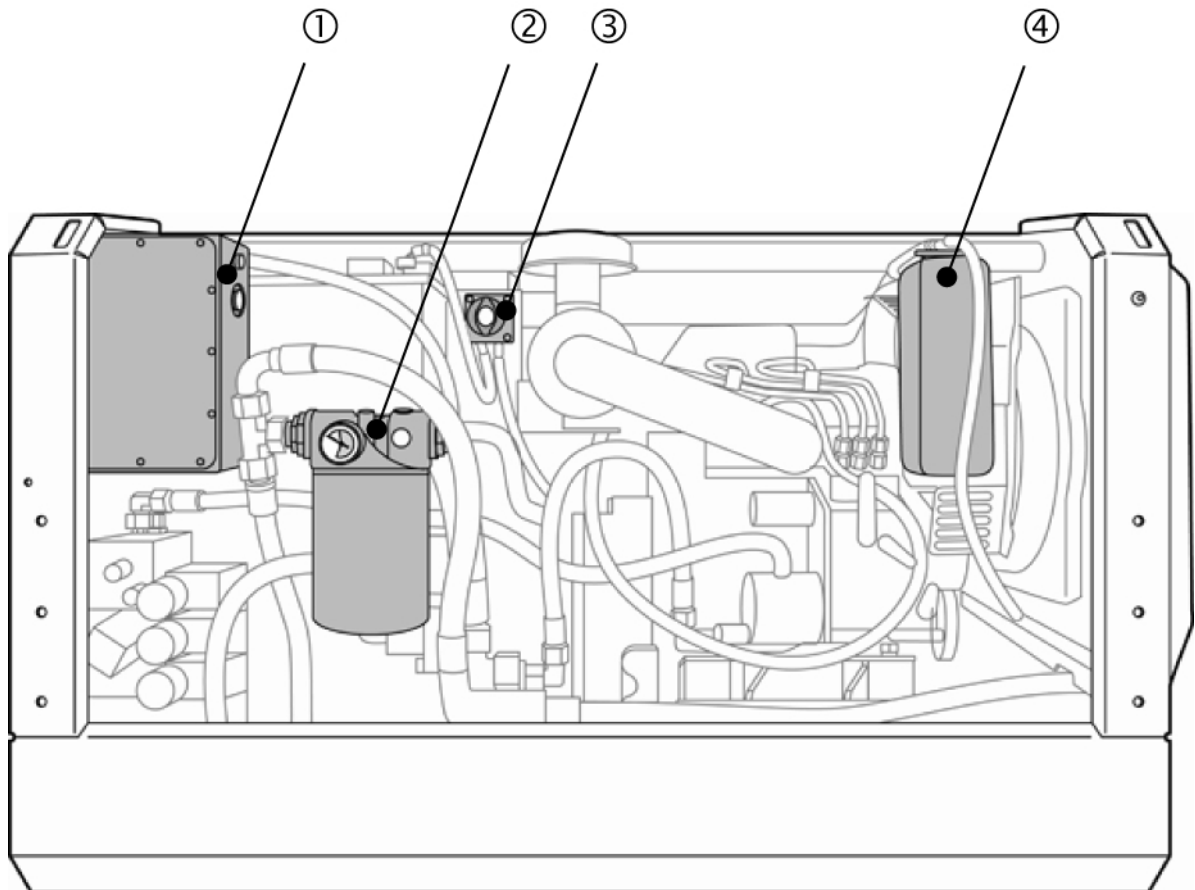

| Pos.-Nr. | Function |
|----------|-----------------------------|
| 1 | Motor control |
| 2 | Hydraulic oil return filter |
| 3 | Master switch |
| 4 | Compensating reservoir |

Overview on rear face of motor unit:

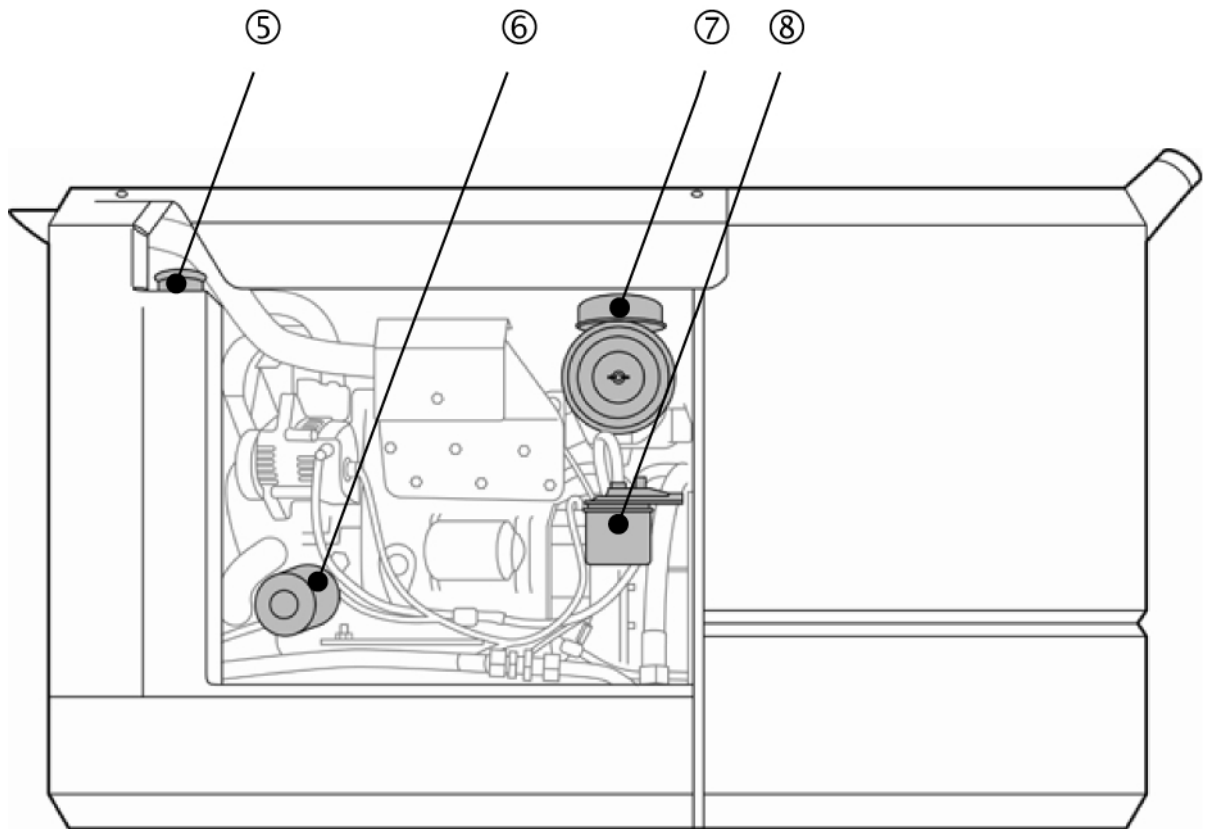

| Pos.-Nr. | Function |
|----------|------------------|
| 5 | Oil filler neck |
| 6 | Motor oil filter |
| 7 | Air filter |
| 8 | Diesel filter |

4.2 Designated use

The motor unit is designed exclusively for conventional use on roads, for park maintenance and for usual winter service work on roads, ways and squares (designated use).

Optionally, the motor unit can be used for snow removal.

Any kind of use that deviates from the procedure set forth herein is considered contrary to its designated use. The operator of the motor unit is liable for any damages arising from such action.

Use, maintenance and reconditioning of the unit may only be carried out by trained and competent personnel.

Operating the plant within the limits of its designated use also involves

- observance of these operating instructions as well as all other enclosed documentation.
- road traffic regulations
- the relevant accident prevention regulations.
- the generally recognized rules relating to technical safety requirements and occupational health.

4.3 Obvious misuse

The motor unit is designed for winter maintenance service. The use of the unit in summer is subject to approval of Kugelmann.

The motor unit is designed for the use on roads and must not be used on slopes like e.g. on ski pistes.

5 Safety instructions

This chapter gives you information on important safety instructions when using the motor unit.

5.1 General safety instructions



caution

Improper handling of motor unit.

Risk of injury or property damage.

- Before operating the motor unit, please study these operating instructions carefully.
 - Please use the unit only for the intended purpose.
 - Do only use original parts and accessories.
 - Do not make any unauthorized changes to the unit.
-

5.2 Special safety instructions



caution

The hydraulic system is under high pressure.

Leaking hydraulic fluid can pass through the skin.

- If any hydraulic fluid that leaks out passes through the skin, seek medical advice immediately.
-



caution

Work at switched on motor unit.

Risk of injury from running machine parts.

- Switch off the motor before opening the tarpaulin cover.
 - Set main switch to *Off* and disconnect battery and remote control before starting to work at the motor unit.
 - Check whether all protection devices are installed and in proper condition.
-

5.3 Transport



warning

Improper transport of motor unit.

Risk of injury or property damage.

- During loading and unloading, do not mount the motor unit at the motor.
 - For loading and unloading of the motor unit, always use the cross rod.
 - Never stay under the motor unit during loading and unloading.
 - Always transport the motor unit horizontally.
-

5.4 Operation



caution

Unprotected operation of motor unit.

Risk of injury or property damage.

- Use the motor unit only if protective plates and ventilation plates are mounted.
-



caution

Improper filling of spreader.

Damage of motor unit due to salt dust.

- Switch off the motor unit and close the tarpaulin cover before filling the spreader with salt.
-

5.5 Maintenance and inspection



caution

Contact with hydraulic oil.

Risk of damage to health.

- Avoid direct contact with skin. Wear protective clothing, especially impervious gloves.
 - Wear protective goggles. If hydraulic oil gets into your eyes, flush with water for at least 15 minutes.
-



caution

Contamination of hydraulic hoses.

Damage at motor unit.

- When inserting the hydraulic hoses, please make sure that those are free of dirt and chips.
-



caution





Metal parts on the battery.

Risk of short circuit.

- Do not place any metal parts as e.g. tools on the battery.
-

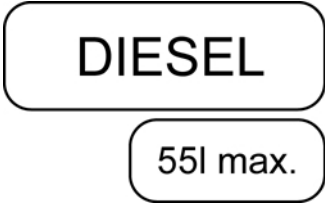
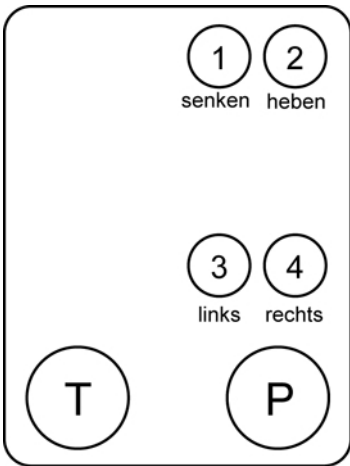
5.6 Designation

You find the following designations on the motor unit:

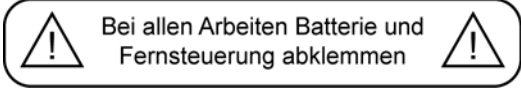
| Marking left-hand side | Explanation |
|---|---|
|  <p>DIESEL</p> <p>55l max.</p> | <p>Filler opening of diesel tank and indication of max. filling volume. For more information regarding the diesel engine, see the enclosed documentation of KUBOTA.</p> |
|  <p>1 2 senken heben</p> <p>3 4 links rechts</p> <p>T P</p> | <p>Pin assignment for hydraulic system.</p> |
|  <p>FERN</p> | <p>Connection for remote control. For further information see <i>Remote control</i>, page 22.</p> |
|  <p>PFLUG</p> | <p>Connection for operating panel of plough control.</p> |
| Marking right-hand side | Explanation |
|  <p>ÖLSTAND KALT></p> <p>HYDRAULIKÖL HLP SYNTH 32</p> | <p>Marking up to which (cold) oil must be filled, and type of prescribed hydraulic oil. For further information see <i>Oil filling</i>, page 17.</p> |
| Marking in the interior of the unit | Explanation |
|  <p>Bei allen Arbeiten Batterie und Fernsteuerung abklemmen</p> | <p>Important safety information for all works at motor unit</p> |

6 Commissioning

This chapter informs you on necessary precautions that have to be taken when commissioning the motor unit.

For details relating to commissioning of diesel engine, please see the enclosed documentation by KUBOTA.

6.1 Hoses and pipelines



caution

Contamination of hydraulic hoses.

Possible damage of motor unit.

- When inserting the hydraulic hoses, please make sure that those are free of dirt and chips.
-

For further information on insertion of hydraulic hoses see *Hints relating to assembly and disassembly, page 34*.

6.2 Oil filling

In delivered condition, the motor unit is filled with hydraulic oil. After first commissioning of the unit, oil must be refilled to compensate the displacement.

The oil tank is located at the rear side of the motor unit on the left side.

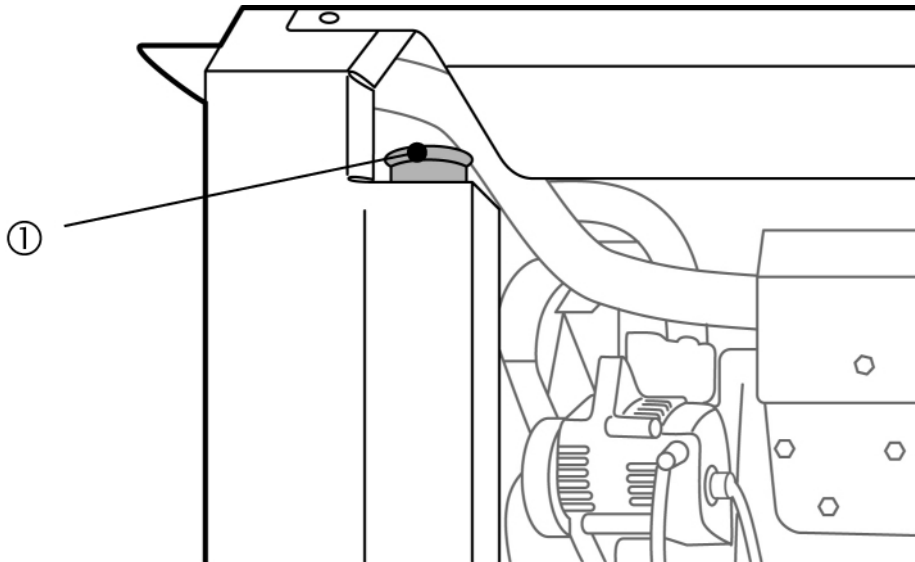

| Pos.-Nr. | Function |
|----------|-----------------|
| 1 | Oil filler neck |



notice

Make sure that oil is filled in only up to the marking. If too much oil is filled in, oil runs out of the ventilated lid in case of expansion.

You will find the oil level marker at the right hand side of the motor unit.

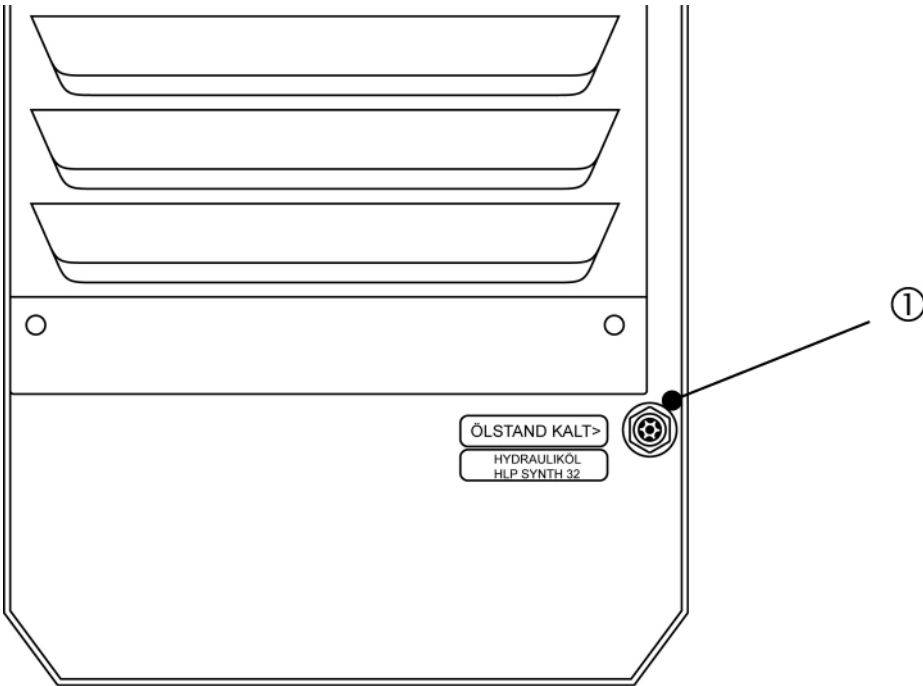

| Pos.-Nr. | Function |
|----------|------------------|
| 1 | Oil level marker |

**notice**

- For refilling, only use the hydraulic oil HLP SYNTH 32.
- Only use hydraulic oil of contamination class 20/18/15 or higher (according to ISO 4406/1999).
- Make sure that oil pan and oil funnel are free from dirt.

**notice**

For refilling, we recommend an oil funnel of this type:

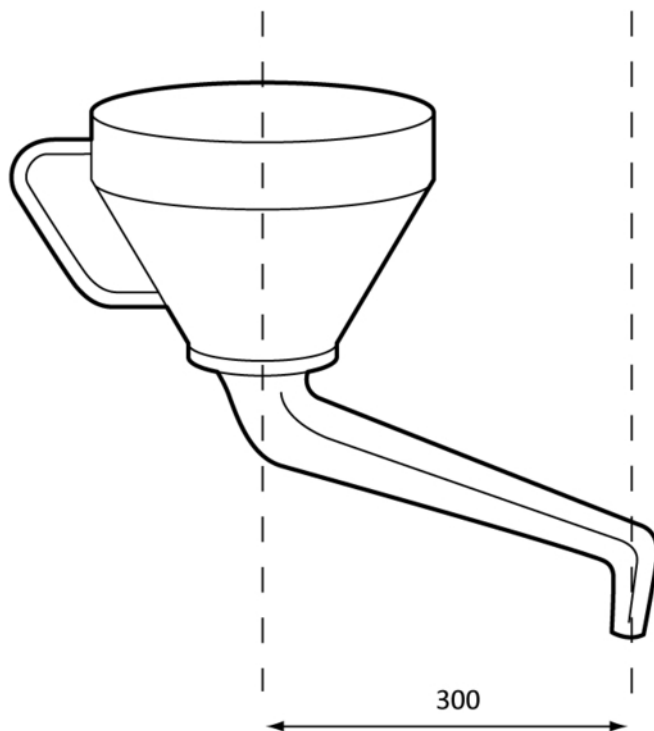

7 Operating instructions

This chapter gives information on the designated use of the unit. Moreover, you get information on how to eliminate simple errors.

7.1 Normal and safe operation

Switch on the motor unit as follows:

1. Set the main switch to *ON*.

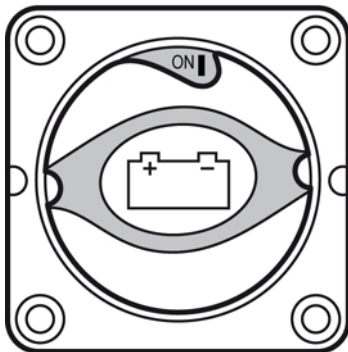

You will find the main switch inside at the rear panel of the motor unit (see *Components, page 10*).

2. Switch on the motor control.

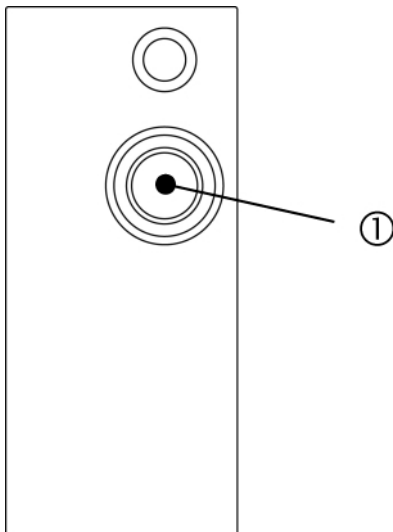

| Pos.-Nr. | Function |
|----------|--------------|
| 1 | Start button |

You will find the motor control at the front face of the motor unit, on the left-hand side (see *Components, page 10*).

The LED display of the control unit signalizes the operating state of the engine.

You will find the control panel at the left hand side of the motor unit.

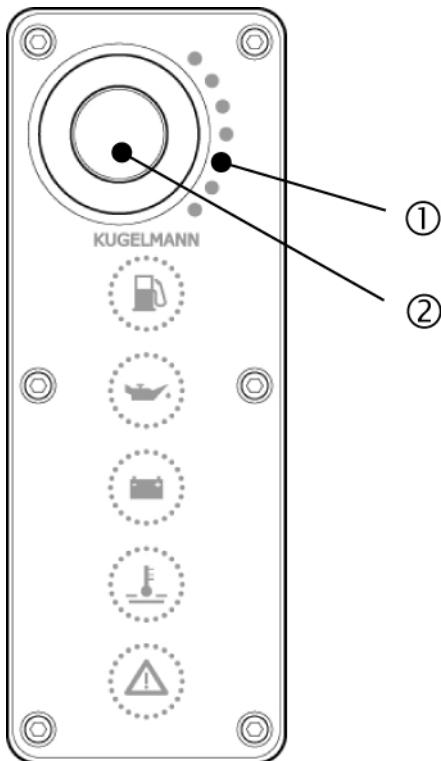

| Pos.-Nr. | Function |
|----------|-------------|
| 1 | LED display |
| 2 | Stop button |

- LEDs are flashing slowly (approx. 20 seconds): The engine is preheating.
- LEDs are flashing rapidly (approx. 2 minutes): Engine is running.
- LEDs are permanently illuminated: Unit is ready to operate.

Switch off the motor unit as follows:

1. Press the stop button (Pos. 2) at the control panel.
The LEDs flash for 2 seconds.
2. Set the main switch to *OFF*.

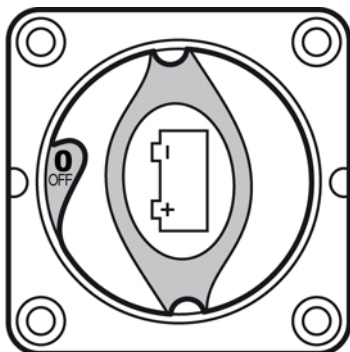

In order to prevent unauthorized persons from starting the motor unit, you can remove the main switch after switching off.

Remove the main switch as follows:

1. Turn the main switch anti-clockwise until it abuts.

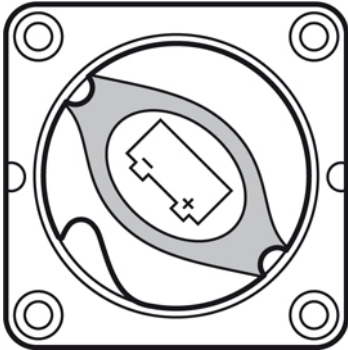

2. Remove the main switch.

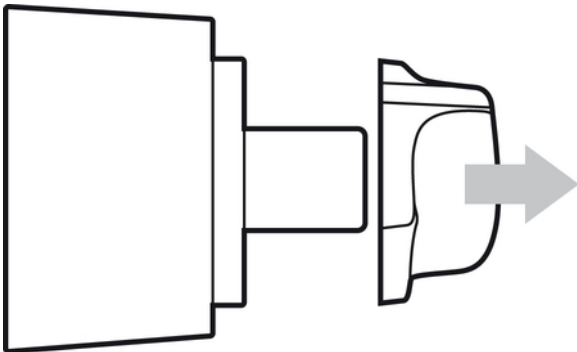

The motor unit cannot be started anymore.

To start the motor unit once again, place the main switch at its proper position and set the switch to *ON*.

7.2 Remote control

You can control the motor unit from the driver's cab by means of the remote control.

7.2.1 Design

The remote control consists of Master and Slave.

The Master (Pos. 1) is the operating unit in the driver's cab. All settings related to spreading are made here.

The Slave (Pos. 2) is the switching electronics at the rear of the spreader. The Slave controls the hydraulic valves of the motor unit.

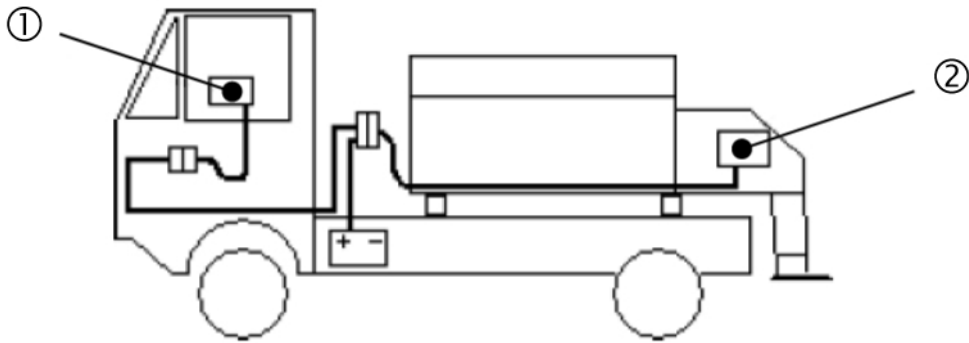

| Pos.-Nr. | Function |
|----------|----------|
| 1 | Master |
| 2 | Slave |

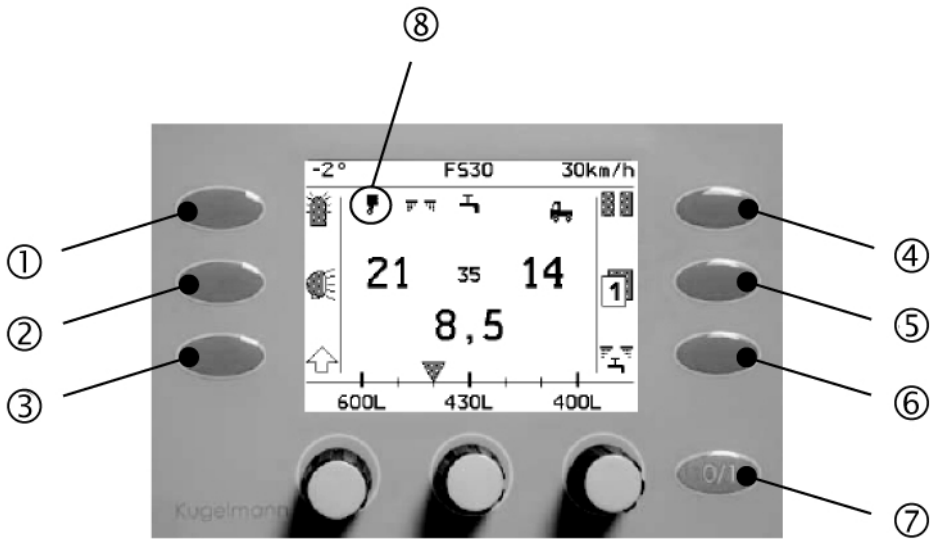

7.2.2 Operating elements

The master consists of the following operating elements:



| Pos.-Nr. | Function |
|----------|----------------------------|
| 1 | Button 1 |
| 2 | Button 2 |
| 3 | Button 3 |
| 4 | Button 4 |
| 5 | Button 5 |
| 6 | Button 6 |
| 7 | Button <i>ON/OFF</i> |
| 8 | Display of operating state |

The following symbols in the display range give you information on the operating state of the motor unit:

| Symbol | Explanation |
|---|----------------------------------|
|  | Motor unit is running. |
|  | Motor unit not running. |
|  | Motor unit preheats or warms up. |

For further information on the operating elements of the remote control, please see the enclosed documentation relating to k-tronic.

7.2.3 Starting the motor unit

In order to operate the motor unit via remote control, the key switch of the motor unit must be set to 0 (see *Normal and safe operation, page 20*).

Starting of motor unit as follows:

The display shows .

1. Hold down button 3 .

The symbol of button 3 changes to .

Display changes to .

2. Press button 1
Short tipping is enough, because the starting pulse is saved in the control system.
3. Release button 3.
Preheating of engine is indicated. Depending on temperature, this procedure may take up to 25 seconds.



The display indicates

As soon as the motor unit has started, warming up of the engine begins. This procedure takes approx. 120 seconds.



The preheating light goes out and display changes to

7.2.4 Switching off the motor unit

Switch off the motor unit as follows:



The display shows

1. Hold down button 3 

The symbol of button 3 changes to 

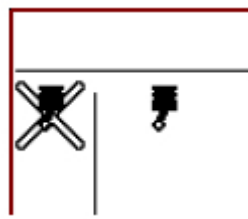

Display changes to

2. Press button 1
Short tipping is enough to switch off the motor unit.



Display changes to

3. Release button 3.

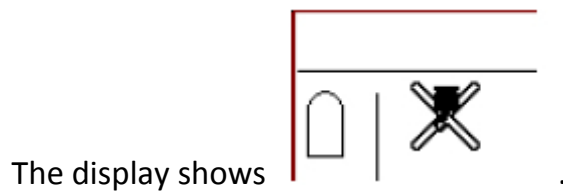

The display shows

If, contrary to expectations, the motor unit switches off during driving, the display

changes from  to .

For further information on the remote control, please see the enclosed documentation relating to k-tronic.

For further information on the plough control, please see the enclosed documentation by Schmidt.

7.3 Extraordinary situations

The warning lamps of the control display indicate errors during the operation of the motor unit:

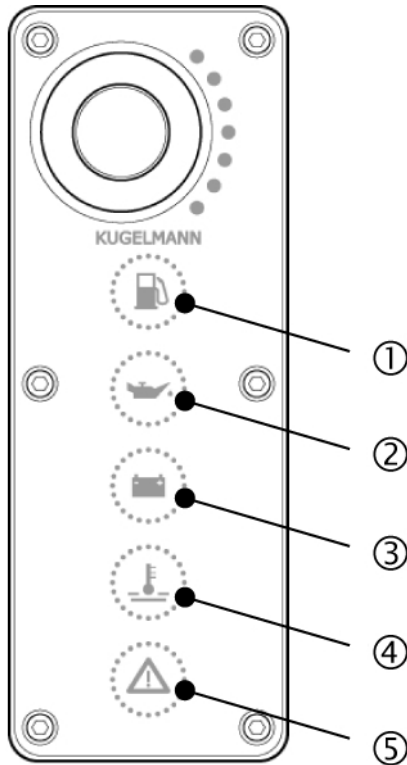

| Pos.-Nr. | Function |
|----------|-------------------|
| 1 | Tank reserve lamp |
| 2 | Oil pressure |
| 3 | Load control |
| 4 | Water temperature |
| 5 | General error |

| Error | Possible cause | Remedial action |
|-------------------|--------------------------------|-----------------------------|
| Tank reserve lamp | Tank is only filled by max. ¼. | Refill fuel |
| Oil pressure | Engine not running | Start engine |
| Load control | Battery or generator defective | Service required (workshop) |
| Water temperature | Cooling system defective | Service required (workshop) |

For all other errors, please contact our customer service (see *Service information*, page 6).

8 Maintenance

This chapter gives information on service intervals for the motor unit and on necessary maintenance work.

8.1 Maintenance intervals

In order to ensure proper operation, please carry out the following maintenance work in the indicated time intervals:

| Interval | Work |
|---------------------------------------|---|
| Before each use | Check coolant level |
| | Check hydraulic oil level |
| | Check cooler for fouling |
| Weekly | Check return filter for hydraulic oil and replace, if necessary |
| Every 200 hours | 1st change of motor oil |
| | Replace engine oil filter |
| Every 500 hours | Replace fuel filter |
| | Change of hydraulic oil |
| | Cleaning of hydraulic oil filter |
| Every 500 hours, at least once a year | Second and following oil changes |
| | Replace engine oil filter |
| | Clean air filter |

For further information regarding maintenance of the engine, please refer to the enclosed documentation of KUBOTA.

8.2 Cleaning of hydraulic oil suction filter



caution

Contact with hydraulic oil.

Risk of damage to health.

- Avoid direct contact with skin. Wear protective clothing, especially impervious gloves.
- Wear protective goggles. If hydraulic oil gets into your eyes, flush with water for at least 15 minutes.

Clean the hydraulic oil suction filter as follows:

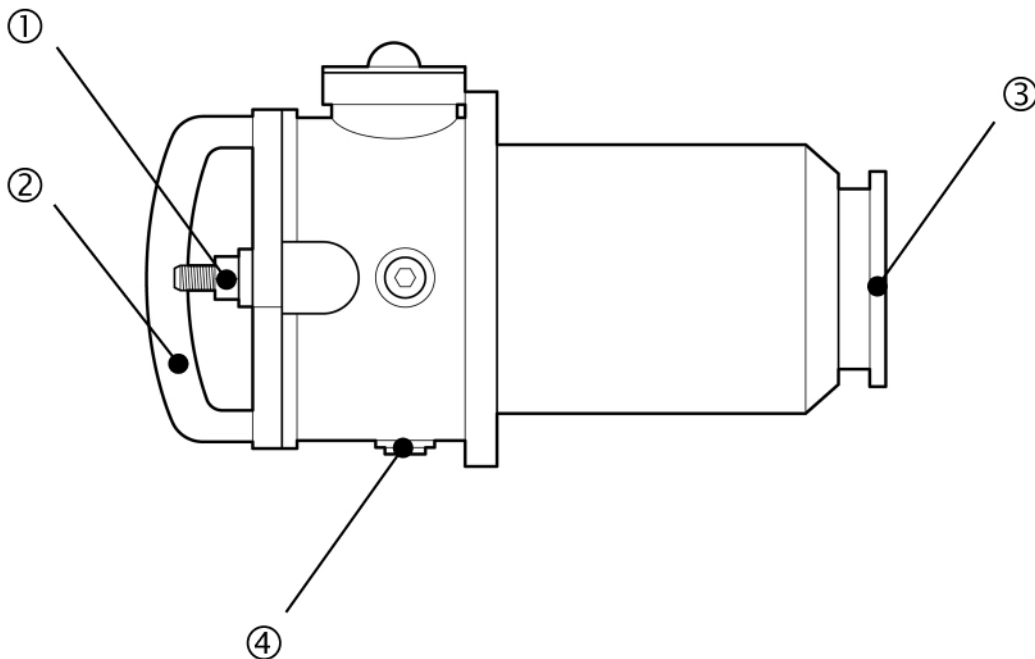

| Pos.-Nr. | Function |
|----------|--------------|
| 1 | Nuts |
| 2 | Handle |
| 3 | Bottom valve |
| 4 | Drain screw |

1. Slacken the nuts (Pos. 1) at the housing of the oil filter and turn them to the end of the screw thread.
2. Pull the flange at the handle (Pos. 2). The bottom valve (Pos. 3) closes.

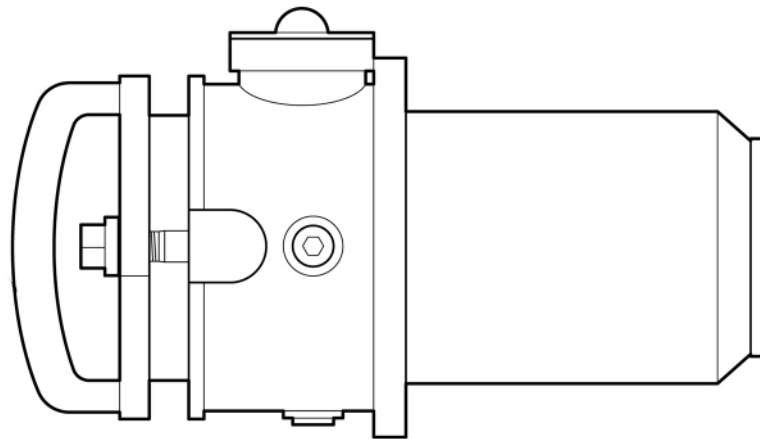

3. Slacken the drain screw (Pos. 4) and slowly turn it out. Use an Allen key 5 mm.
4. Let the remaining oil pour out of the cartridge.
5. Collect the remaining oil in an appropriate vessel.
6. Turn the handle (Pos. 2) anti-clockwise and pull out the lid.

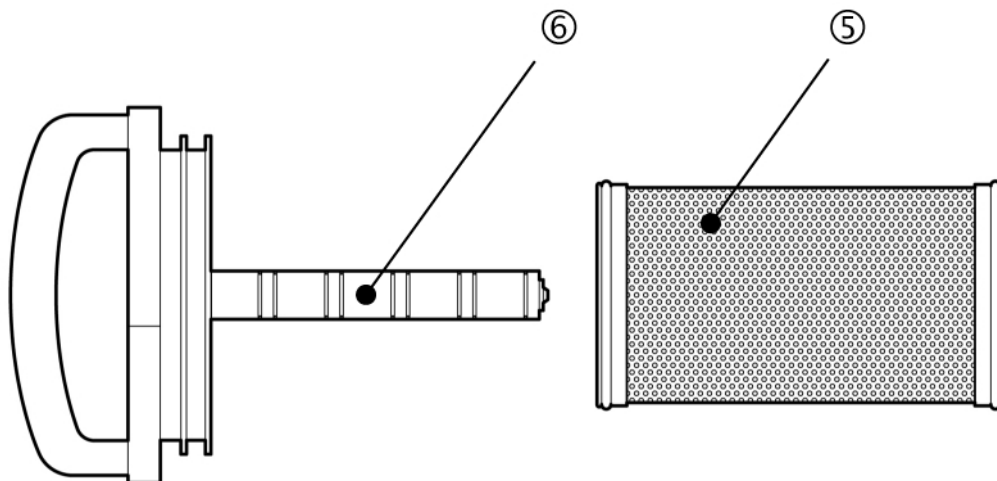

| Pos.-Nr. | Function |
|----------|---------------|
| 5 | Filter insert |
| 6 | Magnetic core |

7. Unscrew the filter insert (Pos. 5) from the lid.
8. Check the magnetic core (Pos. 6) for fouling and clean it, if necessary.
9. Thoroughly blow out the filter insert with compressed air.



caution

Flying dirt particles may get into your eyes.

Danger of eye injury.

- If you blow out the filter insert with compressed air, please wear protective goggles.

10. Screw down the drain screw and tighten it firmly.
11. Insert the lid.
12. Screw down the nuts at the housing.

8.3 Change of hydraulic oil return filter

The motor unit contains a return filter for the hydraulic oil.



notice

Check the return filter weekly. If the contamination indicator reaches the red field at the filter head, it is necessary to replace the return filter.

To change the return filter, unscrew the filter cartridge and replace it by a new one.

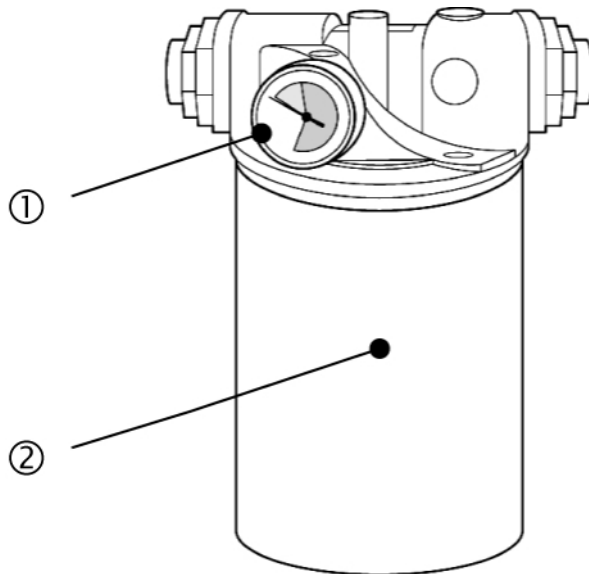

| Pos.-Nr. | Function |
|----------|-------------------------|
| 1 | Contamination indicator |
| 2 | Filter cartridge |

9 Transport

This chapter informs you on necessary precautions that have to be taken when transporting the motor unit.



warning

Improper transport of motor unit.

Risk of injury or property damage.

- During loading and unloading, do not mount the motor unit at the motor.
- For loading and unloading of the motor unit, always use the cross rod.
- Never stay under the motor unit during loading and unloading.
- Motor unit may not be tilted.

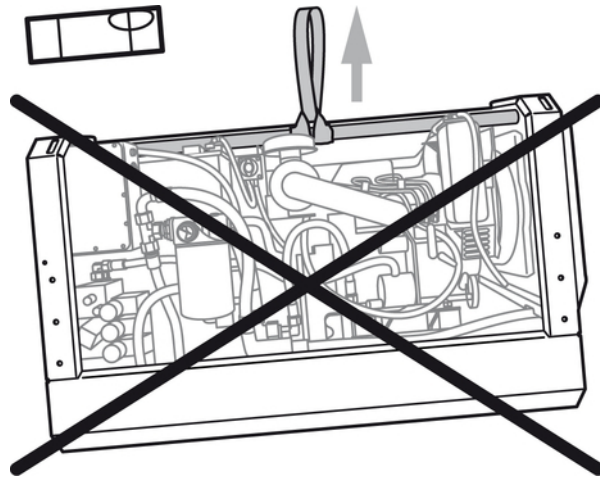

Make sure that the motor unit is always transported horizontally. Fix it exactly in the center of the cross rod.

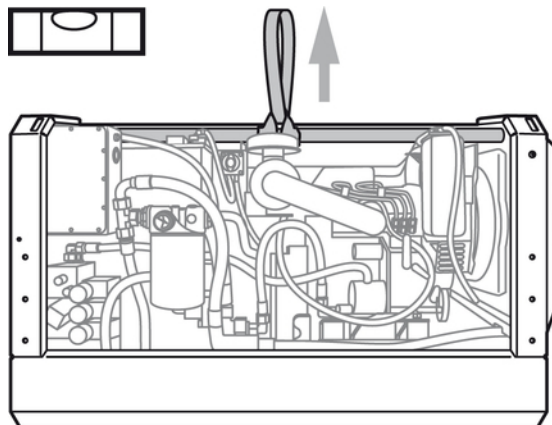

10 Storage

This chapter informs you on necessary precautions that have to be taken when putting the motor unit into stock.



notice

- Always store the motor unit in mounting position.
 - Always store the motor unit refueled.
 - Always store the motor unit in a dry place.
 - Check the oil and water level before placing it into storage. Make sure that the oil and water tanks are filled.
 - Cover the tail pipe to protect the motor unit from impurities.
 - If you disconnect the hydraulic hoses, close the ends with sealing plugs.
 - Clean the interior of the motor unit with a high-pressure cleaner to prevent the formation of salt stone.
 - After cleaning, seal the motor unit inside and outside with a suitable spray wax (e.g. Valvoline Tectyl ML).
-

11 Hints relating to assembly and disassembly

This chapter informs you on necessary precautions that have to be taken when assembling or disassembling the motor unit.



notice

Make sure that the hydraulic hoses are properly installed:

- Consider the laying radii appropriate for the hose. Please refer to the assembly instructions of the hose manufacturer.
 - The hoses must not be crushed.
 - The hoses must not be placed on moving parts as chafe marks could result.
-

12 Disconnecting the system

The motor unit must be disposed of in accordance with local or state regulations. Depending on material, dispose of parts with residual waste or hazardous waste or recycle. Kugelmann takes no responsibility for disposal.







13 Technical Data

| General | |
|--|--|
| Weight | approx. 350 kg |
| Dimensions | 1280 x 870 x 520 mm |
| Fixing on foundation with at least 4 x M12 nuts, property class 8.8 | |
| Engine type | |
| Motor | KUBOTA three-cylinder diesel Type: D1105-E3B |
| Engine power | 16 KW at 2100 rpm (SAE J1995 GP) |
| Fuel | Diesel |
| Tank volume | 55 l |
| Fuel consumption | approx. 4 l/h |
| For more information regarding the engine, see the enclosed documentation of KUBOTA. | |
| Hydraulic system | |
| 1st cycle | Output-controlled axial piston pump (P=7 KW) with p _{max} =230 bar, Q _{max} =40 l/min |
| 2nd cycle (optionally for plough control) | Constant current pump with Q _{max} =13 l/min at p _{max} =180 bar |
| Hydraulic oil | HLP SYNTH 32, contamination class 20/18/15, tank volume 43 l |
| Electrical installation | |
| Battery | 12 V – 95 Ah |
| 24 V from external board net of truck for optional plough control | |
| Ambient conditions and limits for operation | |
| <p>The motor unit is designed for the operation at an external temperature of up to -25°C.</p> <p>If you would like to operate the motor unit at an external temperature of under -25°C, please contact us in advance.</p> | |

14 Spare parts list

The motor unit contains the following spare parts:

| Article number | Spare part |
|----------------|--|
| 10032291 | Oil filter engine  |
| 10033222 | Oil filter hydraulic system (suction) 100 µm  |
| 10033223 | Oil filter hydraulic system (return motion) 10 µm  |
| 10032290 | Air filter insert  |
| 10032751 | Water cooler |
| 10033226 | Oil cooler |

| Article number | Spare part |
|----------------|---|
| |  |
| 10033227 | Delivery pump Diesel  |
| 10033228 | Diesel filter  |
| 10033229 | Flexible hose exhaust  |
| 10034545 | Speed sensor 3/8" (up to 2010)  |
| 10029573 | Battery 12 V – 95 Ah  |

| Article number | Spare part |
|----------------|--|
| 10032752 | Compact exhaust |
| 10033230 | V-belt 9.5 x 950 La  |
| 10035378 | Tank selector reserve  |

Appendix

The Appendix contains

- an overview on the hydraulic cycle of the motor unit
- an overview on the terminal allocation at the spreader

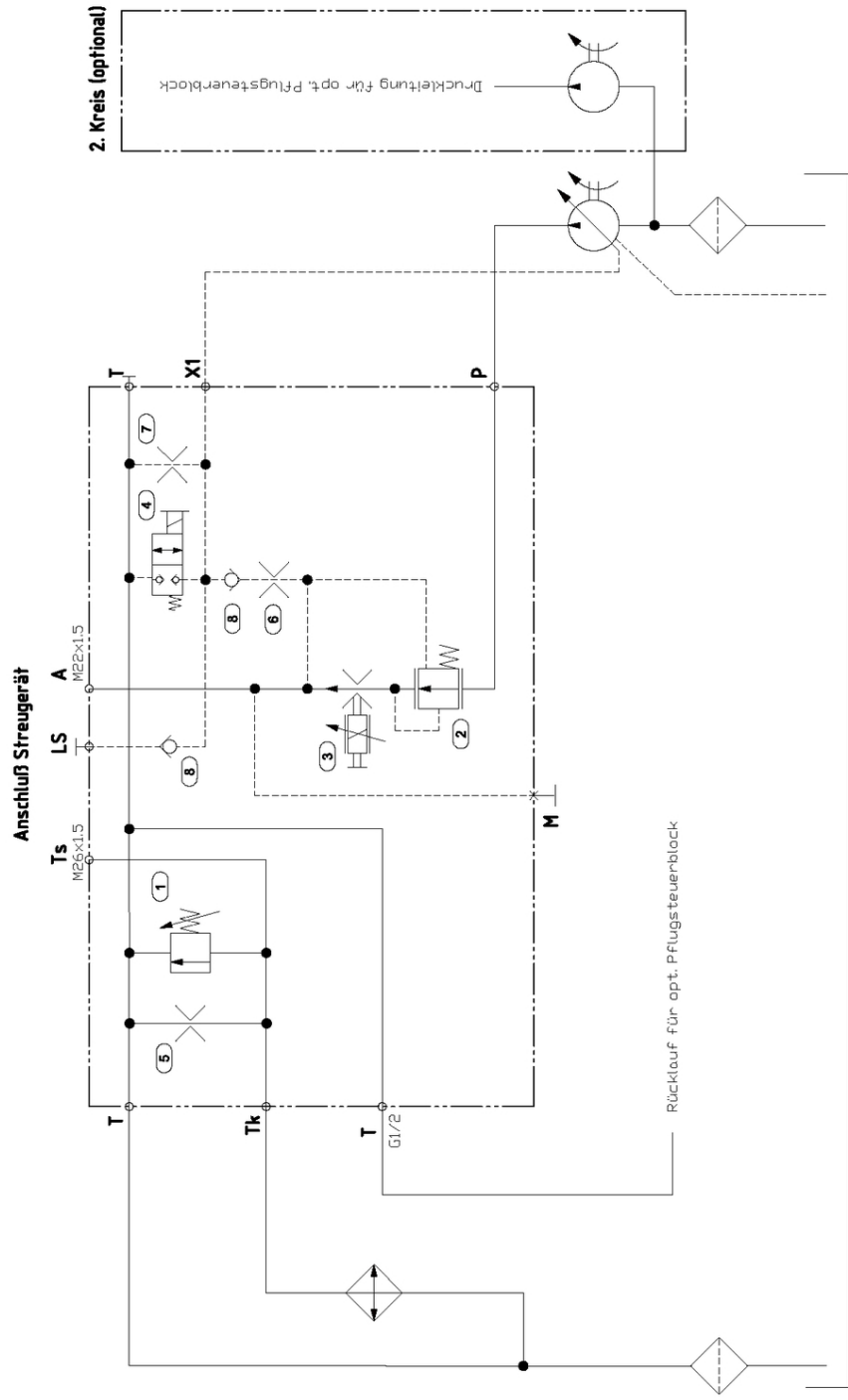

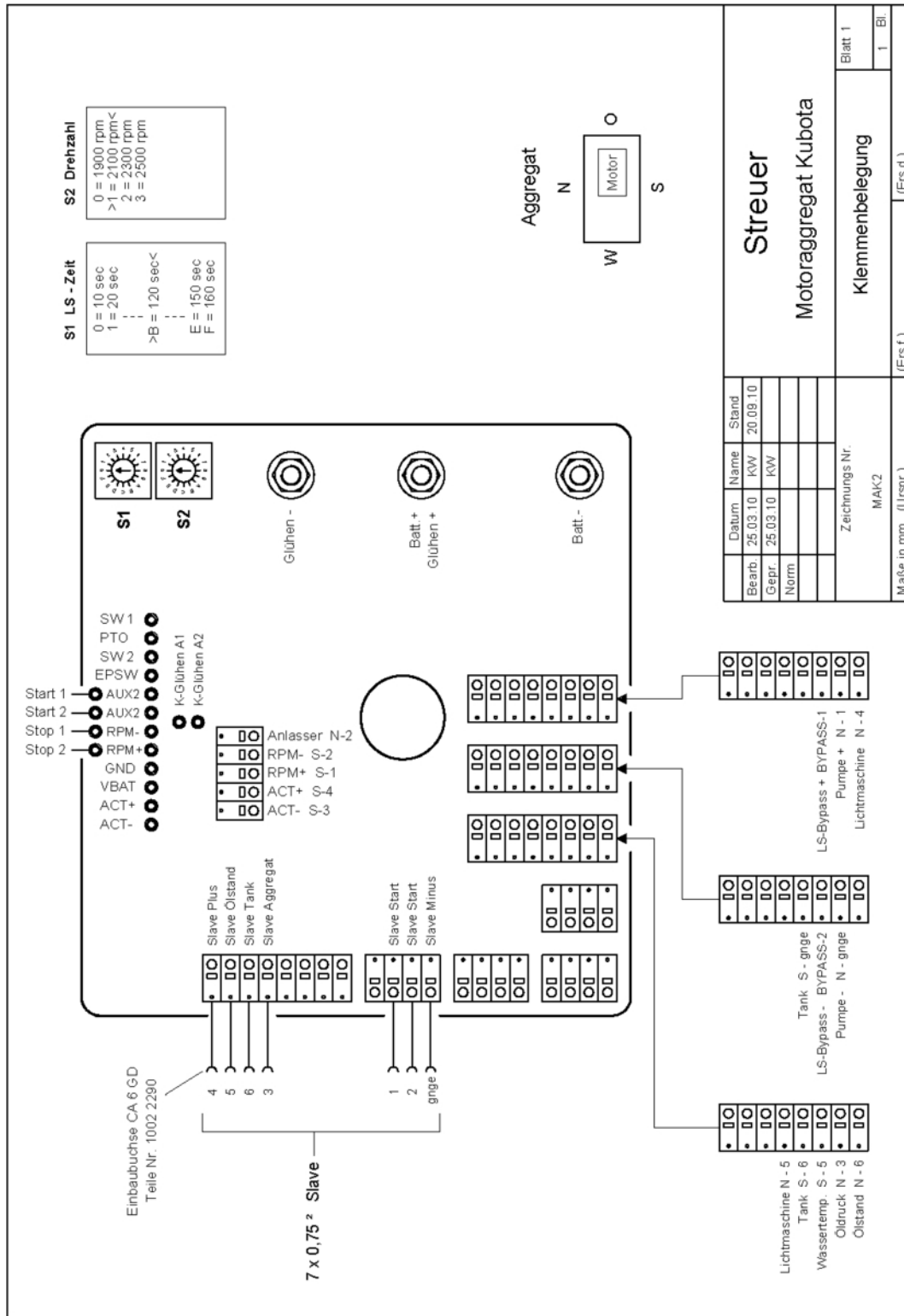

Index

| | | | |
|---|--------|---|--------|
| A | | I | |
| Appendix..... | 40 | Identification..... | 5 |
| Assembly..... | 34 | | |
| C | | L | |
| Change history..... | 9 | LED display..... | 20 |
| Change of hydraulic oil return filter..... | 31 | Load control..... | 27 |
| Cleaning of hydraulic oil suction filter..... | 29 | | |
| Commissioning..... | 17 | M | |
| Components..... | 10 | Main switch..... | 20 |
| Control display..... | 27 | Maintenance..... | 28 |
| Control panel..... | 5, 21 | Motor control..... | 20 |
| Conventions..... | 9 | | |
| Copyright..... | 2 | O | |
| D | | Oil filling..... | 17 |
| Design..... | 10 | Oil funnel..... | 19, 19 |
| Designated use..... | 12 | Oil level marker..... | 18 |
| Designation..... | 16 | Oil pressure..... | 27 |
| Diesel engine..... | 17 | Oil tank..... | 17 |
| Disassembly..... | 34 | | |
| E | | P | |
| Errors..... | 27 | Pipelines..... | 17 |
| Extraordinary situations..... | 27 | | |
| F | | R | |
| Filling of hydraulic oil..... | 17 | Remote control..... | 22 |
| | | Remote control, Master..... | 22 |
| G | | Remote control, operating elements..... | 23 |
| Guarantee..... | 45, 45 | Remote control, Slave..... | 22 |
| H | | S | |
| Hoses..... | 17 | Safety instructions..... | 13 |
| Hydraulic oil..... | 19 | Servicing..... | 15 |
| | | Spare parts list..... | 37 |
| | | Starting of motor unit..... | 20 |
| | | Starting the motor unit..... | 24 |
| | | Storage..... | 33 |
| | | Switching off the motor unit..... | 25 |
| | | Switching on motor unit..... | 20 |

T

Tank reserve lamp..... 27
Target group..... 8
Transport..... 14, 32
Type plate..... 5

W

Water temperature..... 27

Guarantee

Kugelmann Maschinenbau e.K., 87675 Rettenbach a.A., warrants its machines to be free from defects in material and workmanship and undertakes to replace free of charge all parts ex works which have been purchased by relevant Kugelmann dealers and have been acknowledged as defective after having been checked by Kugelmann. The warranty expressly given shall be limited to a period of 12 months from the date of delivery of the machine to purchaser. All further claims by the customer shall be excluded.

Wear parts are excluded from the guarantee.

The manufacturing company does not provide any guarantee for any products manufactured by third parties; however, the manufacturer shall cede to the buyer any claims it might have against sub-suppliers. Furthermore no guarantee is provided for used, second-hand, modified or converted machines.



notice

Fill in your guarantee card immediately and return it to the manufacturing company. Claims have to be made immediately after occurrence of the damage, at the latest 30 days thereafter, in the form of a written guarantee claim application.

----- ✂

| | |
|---|--|
| <p><i>Company</i> <i>Kugelmann Maschinenbau e.K.</i> <i>Gewerbepark 1-5</i> <i>87675 Rettenbach a.A.</i> <i>Germany</i></p> | <p>Device type:</p> <p>Serial no.:</p> <p>Chassis no.:</p> <p>Year of manufacture:</p> <p>Address of the dealer: </p> <p>Address of the operator/owner: </p> |
|---|--|

I have read the operating instructions.

Signature of the operator:

The guarantee card has to be sent to the manufacturer immediately.

ATTENTION: Warranty claims are only accepted with the warranty card of Kugelmann Maschinenbau e.K.

----- ✂

